

---

CTI VP Norman Mansson Presents Case Studies on De-Bottlenecking

---

## Evaporator and Crystallizer De-Bottlenecking

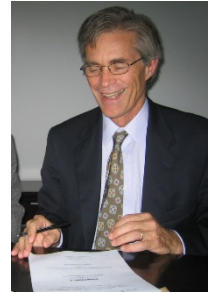

The back end of evaporators and crystallizers contain the mist eliminator, which prevents entrained liquid with dissolved solids (as well as some suspended solids) from being carried over with the steam to the following effect steam chest, where it can foul the steam side of the tubular heat exchanger or the space within a plate type evaporator.

The desire for increased production capacity requires evaluation of the likely resulting increases in vapor flow and higher pressure drop due to the changes in the process conditions. Without redesigning the mist eliminators, there can be loss of product and increased contamination of downstream condensate.

This paper presents (3) different cases where mist eliminators were replaced to increase the capacity of the evaporation process as well as improve performance.

*Case #1*

# Evaporator De-Bottlenecking

## The Problem:

For Effect 6 of an old, rising film, black liquor evaporator in a Florida Kraft paper mill, the existing horizontal flow chevron mist eliminator became the bottle-neck when process conditions (including a greater steam rate) changed, resulting in a high pressure drop, physical deterioration, and liquor re-entrainment. Furthermore, when the evaporator was originally designed, no provision was made to be able to remove the heat exchanger for re-tubing without having to remove the mist eliminators.

## The Solution:

Since vapor head space was sufficient, an AIROL® 430H125 horizontal flow chevron (3-pass design with 1.25" vane spacing) was installed to provide the highest efficiency and the best direct drainage, and to lower the pressure drop to less than the original design before the process change. The AIROL® 430H125 was selected because the optimum vane spacing and number of directional passes still allowed sufficient opening to minimize fouling. Rather than hanging closely mounted mist eliminators, we designed new support beams and re-positioning to allow for the future removal of the heat exchanger without interference with the chevrons. A resulting deck surface on the mist eliminator outlet sides permits maintenance personnel to work without having to install scaffolding. All sections were made in the largest possible sub-assemblies, pre-fitted and verified to minimize field labor. By removing the top flanged vapor head, the old internals and the new large sub-assemblies were replaced quickly, allowing the retrofit to be done within a tight outage schedule, in less than the allocated time frame.

Start-up and full production evaluation confirmed that both condensate quality and pressure drop were within the levels expected. Not only were energy savings realized from the lower pressure drop, but improved condensate quality meant that additional condensate treatment was no longer necessary before reusing that water, and the 65% black liquor, which had been re-entraining, could now be used directly.

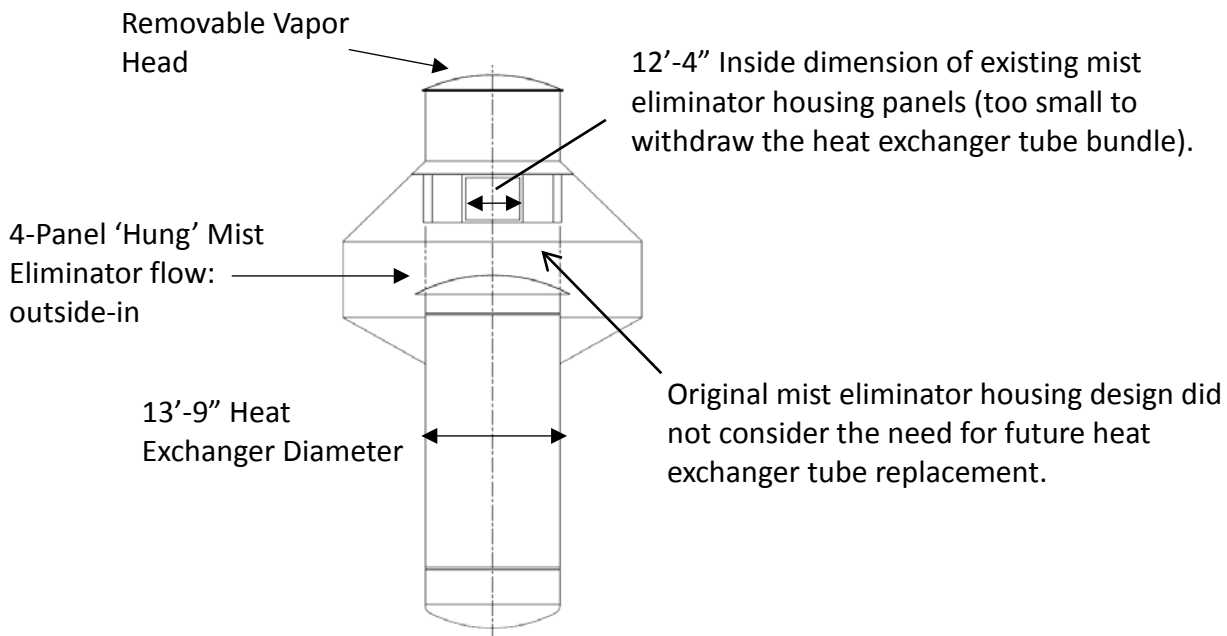

**EXISTING EVAPORATOR ELEVATION**

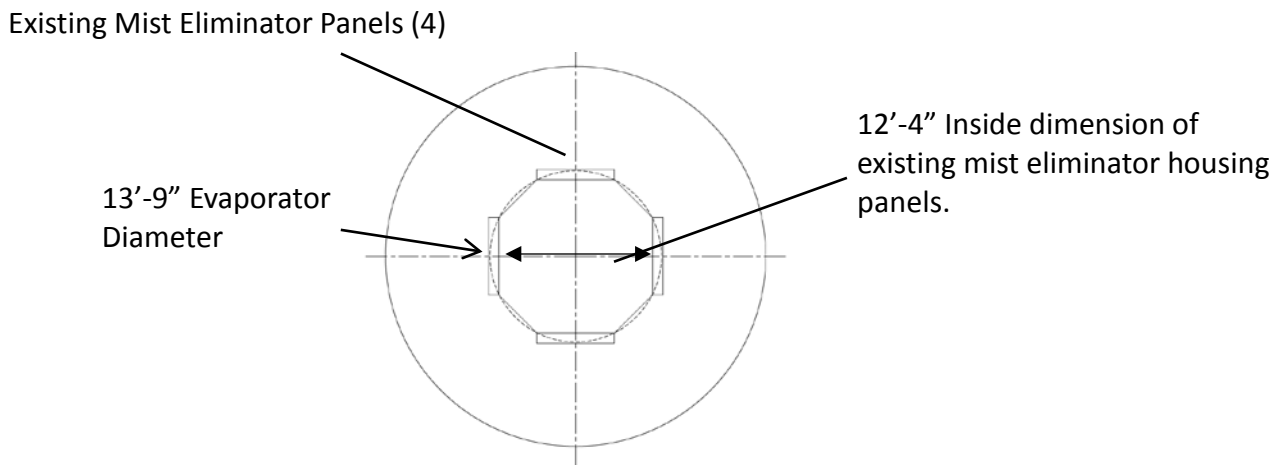

**EXISTING EVAPORATOR PLAN VIEW**

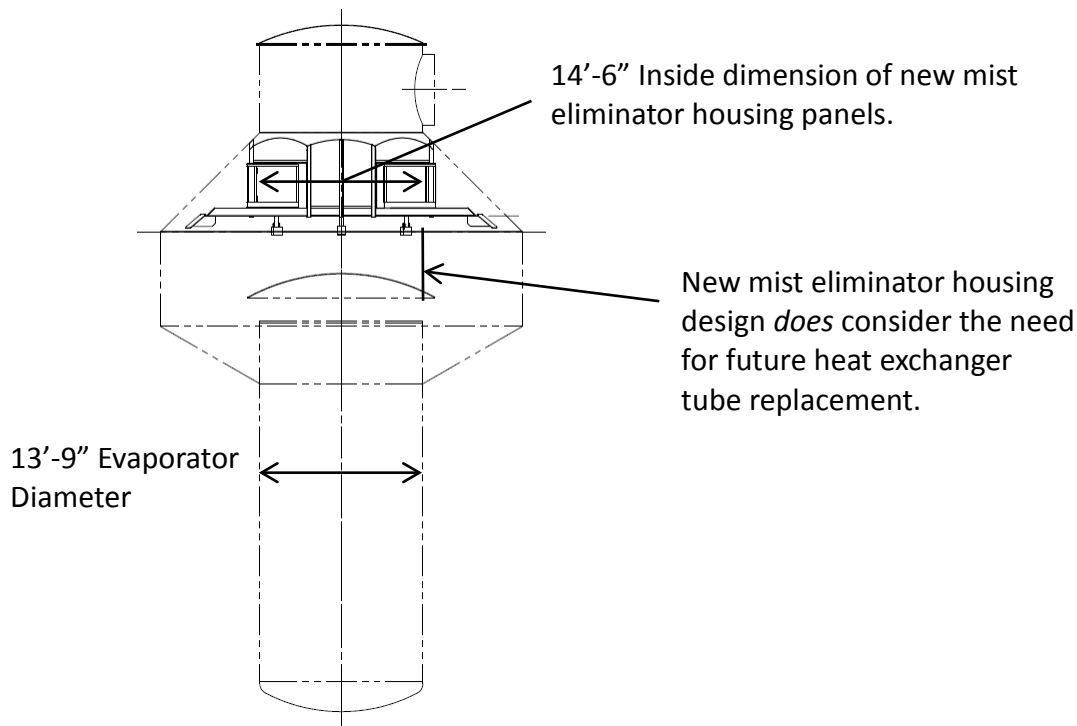

**MODIFIED DESIGN ELEVATION VIEW**

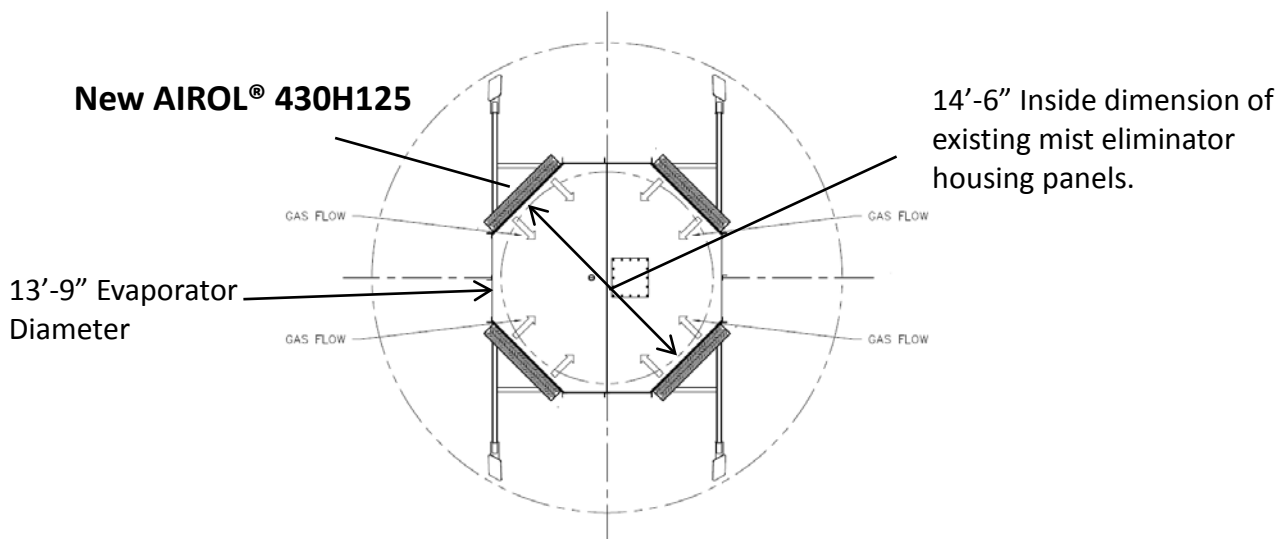

**MODIFIED DESIGN PLAN VIEW**

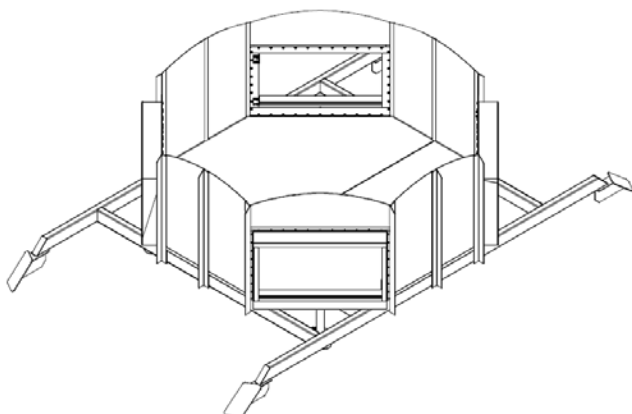

**MODIFIED DESIGN 3D  
TOP VIEW**

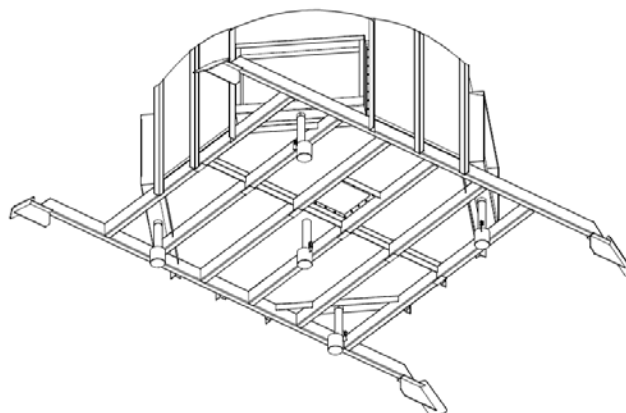

**MODIFIED DESIGN 3D  
BOTTOM VIEW**

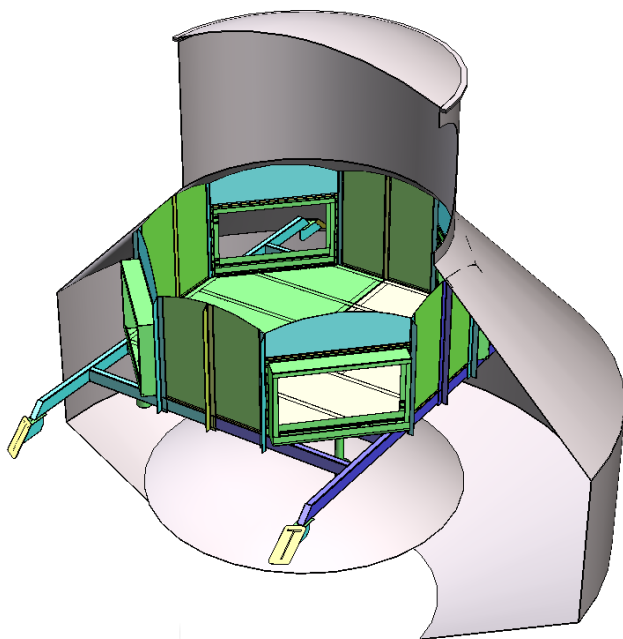

### **CUTAWAY OF EVAPORATOR VAPOR HEAD**

Showing new welded-in supports, blanking, internal decking, and openings for the AIROL® 430H125 mist eliminators.

*Coastal Technologies is the market leader in supplying pulp and paper evaporator mist eliminators world-wide for both new and retrofit applications.*

Case #2

# Crystallizer Process Capacity-Boosting Retrofit

## The Problem:

When the down-stream cyclonic separator was no longer sufficient for the increased production rate of L-Threonine (an amino acid used in the biosynthesis of proteins), and the crystallizer vapor head had insufficient volume for the addition of an internal mist eliminator, the crystallizer manufacturer and plant management needed a solution to boost capacity and minimize pressure drop. They focused on inserting a compact in-line chevron mist eliminator in the vapor line connecting ducts at the top of 180° elbows.

## The Solution:

CTI was selected as the vendor for this application, in part due to our extensive experience with L-Lysine evaporation applications, as well as our past successful record with the evaporation manufacturer.

CFD modeling indicated sufficient pressure drop was needed to assure uniform flow distribution. The vessel, with stiffening, was subsequently designed to run at full vacuum, due to the operating conditions, and FEA proved the design would meet ASME Code purposes.

A higher efficiency AIROL® 430H100 horizontal flow chevron (3-pass with 1" vane spacing) was selected and inserted in a short, straight section of ducting. One turning vane was added to the inlet elbow and included as part of the mist eliminator housing to minimize the required field work. Additionally, since this was a crystallizer application with a down-stream turbo compressor, and the user had no experience with chevrons in the service, an inlet wash header/nozzle on a withdrawal nozzle was added so the mist eliminator could be washed online without any carryover.

The field installation was accomplished with ease due to the flawless fit-up, and pressure drop was minimized with the added inlet turning vane. The pressure drop and steam condensate quality were confirmed within the specification requirements.

# Chevron Mist Eliminator Field Retrofit with Limited Space

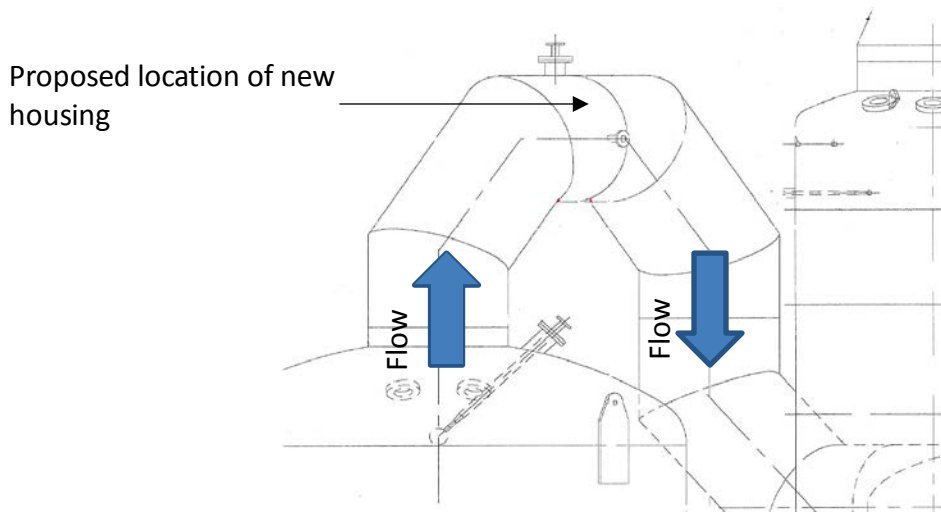

## ORIGINAL VAPOR DUCTING LAYOUT

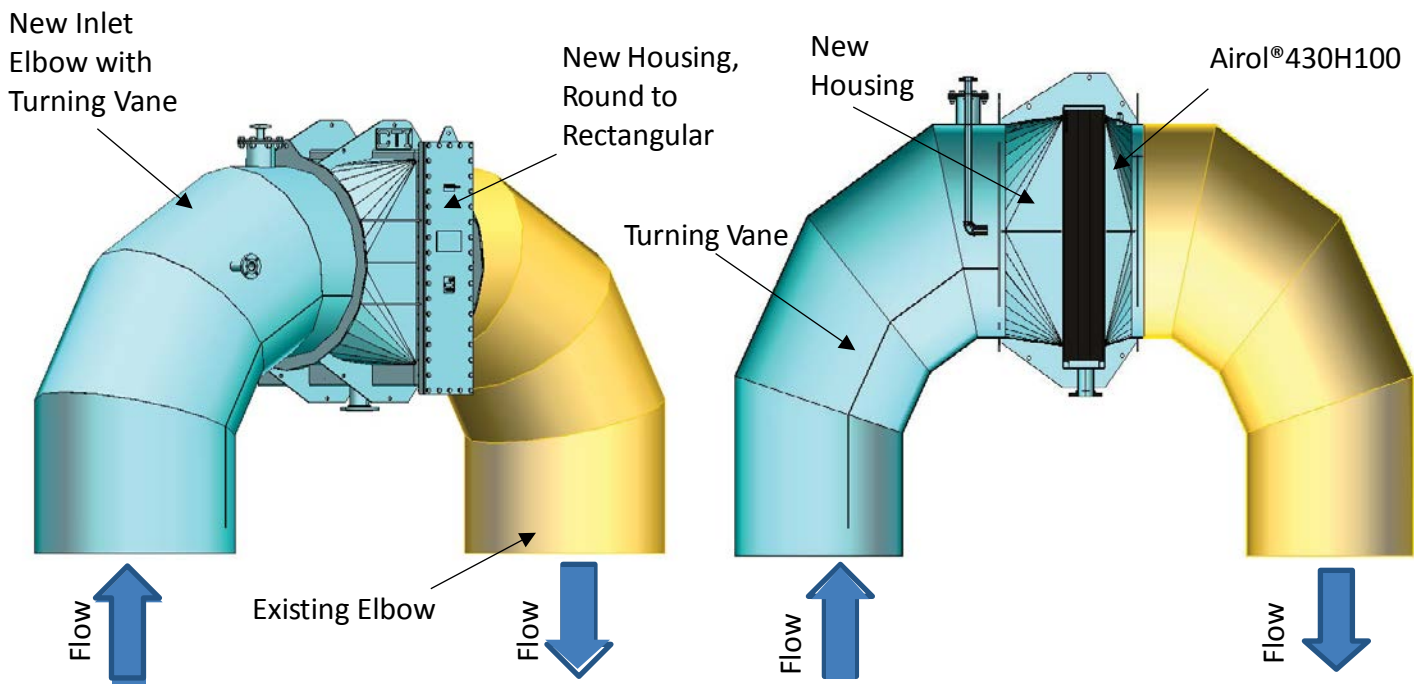

**NEW HOUSING  
INSTALLED LAYOUT**

**NEW HOUSING  
ELEVATION SECTION VIEW**

# Chevron Mist Eliminator Field Retrofit with Limited Space

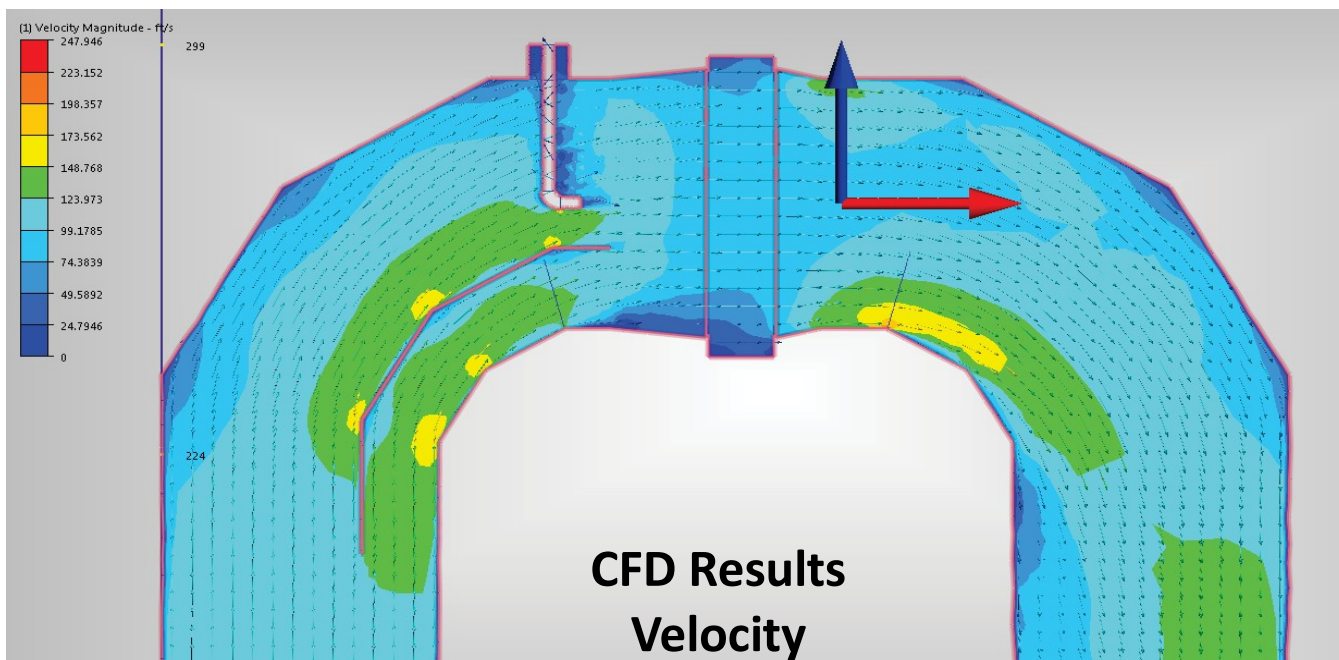
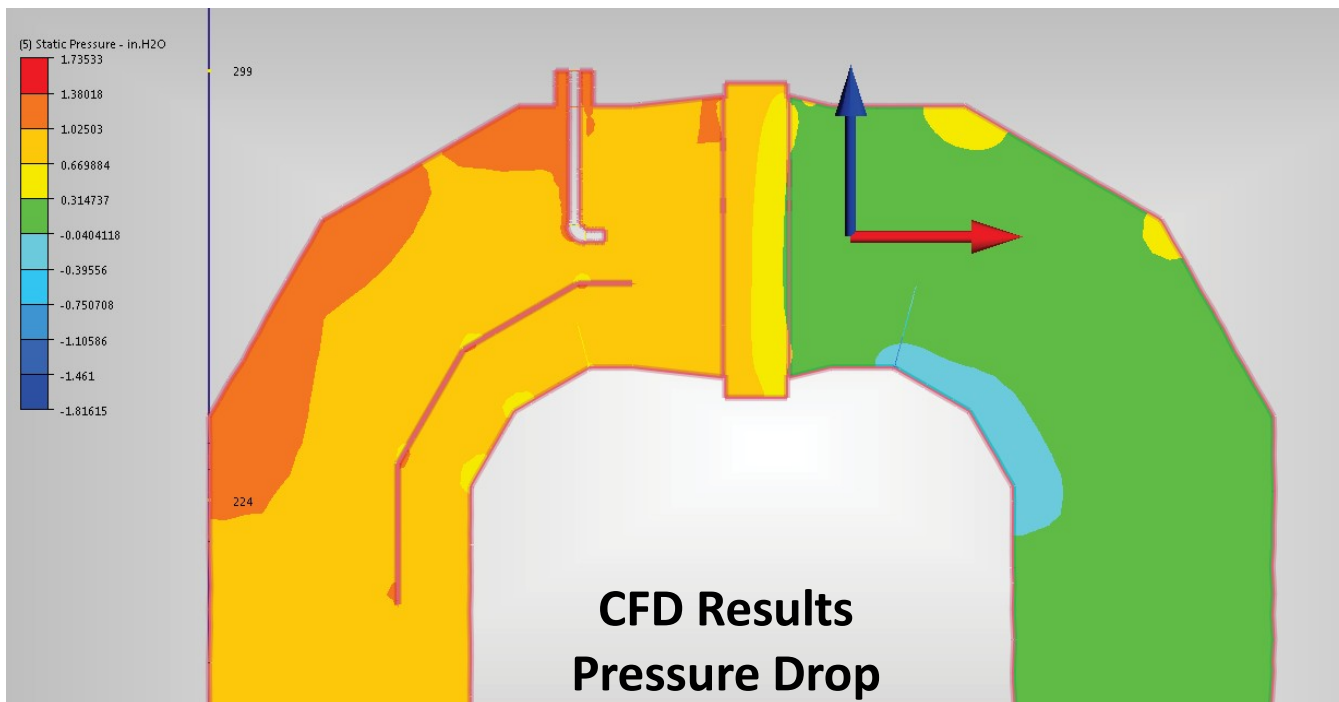



Case #3

# Replacing an Existing External Inline Mist Eliminator

## The Problem:

A planned increase in production capacity at this South Carolina paper mill was projected to cause significant black liquor carry-over from the 1st effect evaporator to the steam chest of the 2nd effect, as well as a high pressure drop.

Previous upgrades adding a new, larger heat exchanger and a now-outdated large external mist eliminator left no room in the vapor head for expansion. Ironically, the existing mist eliminator housing could not be utilized to increase capacity because it was *too* large. The sudden great expansion of steam entering the transition housing would create poor flow distribution across the mist eliminator, and trying to fit new mist eliminator internals within the housing would result in poor steam flow.

## The Solution:

Design improvements during the past (10) years permitted a new mist eliminator to have a smaller cross section and to operate with a lower pressure drop, and Computational Fluid Dynamic modeling (CFD) verified that the addition of turning vanes would assure uniform vapor flow across the new mist eliminator, so the vanes were added to the existing inlet and outlet elbows. An inlet wash system and a top wash header was provided to clean the mist eliminator online without carry-over.

The transitional housing needed to be designed for full vacuum and 15 psig, and the housing and stiffening design was verified using Finite Element Analysis (FEA).

The housing with mist eliminator and wash system was delivered completely assembled. The inlet and outlet elbow turning vanes were delivered in a bolt-together/weld together manner with clear instructions. The transitional housing was replaced within the available dimensional limits with vapor duct, flanged connections to match the existing lines, and were field bolted and welded. An existing deck was reconfigured to allow access to the mist eliminators from the side (as before), as well as from a large new top platform from where, with the mist eliminator access cover removed, the top wash header can be removed and serviced, and all (10) chevron modules can be examined and jet washed without removal. The new top platform with railings and ladders were pre-fit, and knocked down for shipment.

## REMOVE THE EXISTING MIST ELIMINATOR HOUSING

Cut loose the inlet and outlet duct flanges.

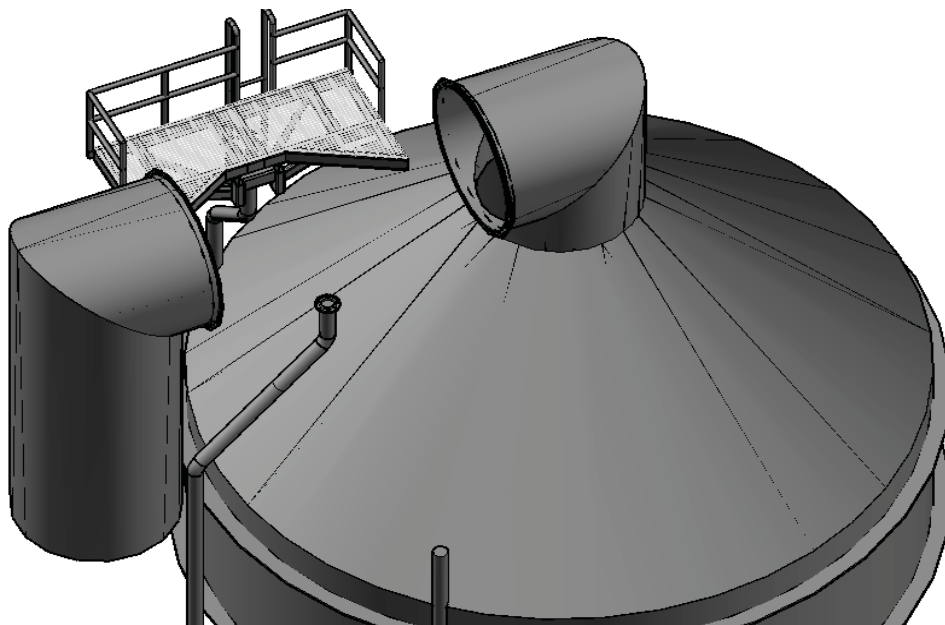

**EXISTING MIST ELIMINATOR HOUSING REMOVED.**

Remove the tapered portion of the existing platform, typical both sides.

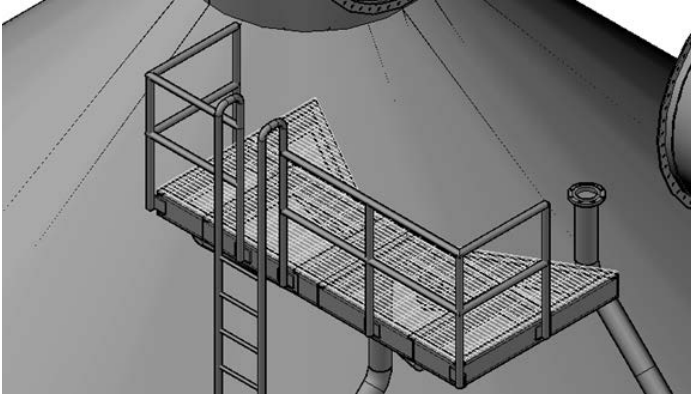

Before

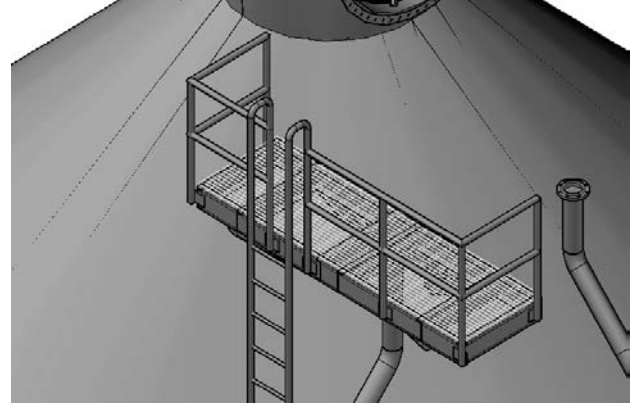

After

**PLATFORM MODIFICATION**

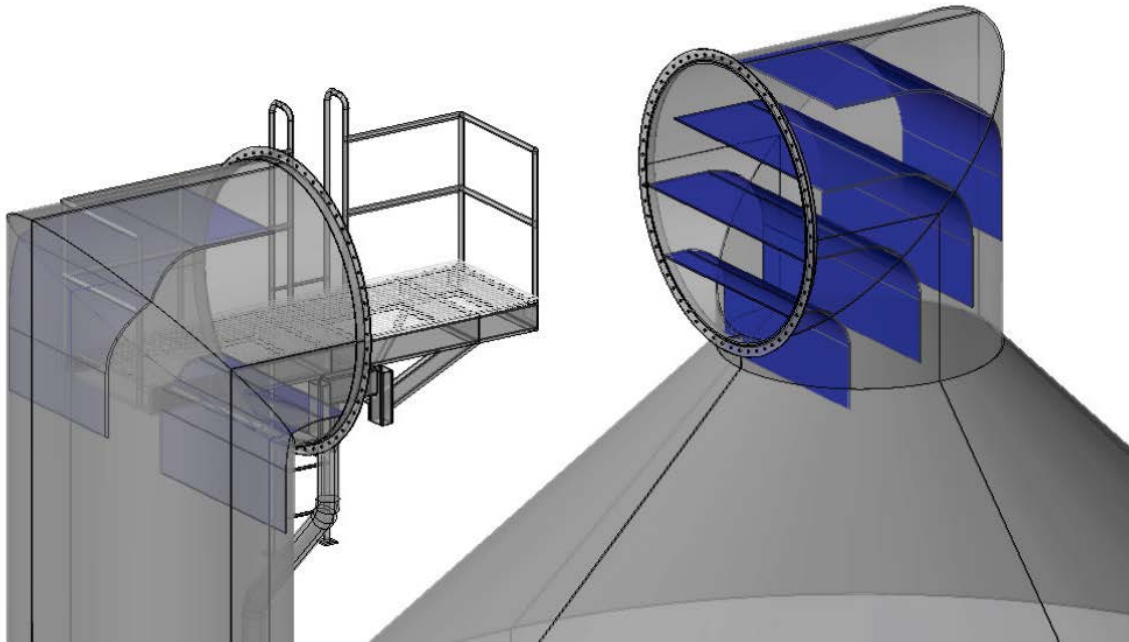

**INSTALLED INLET AND OUTLET TURNING VANES**

**MIST ELIMINATOR ASSEMBLY PRE-FABRICATED TO BE INSTALLED IN (1) LIFT**

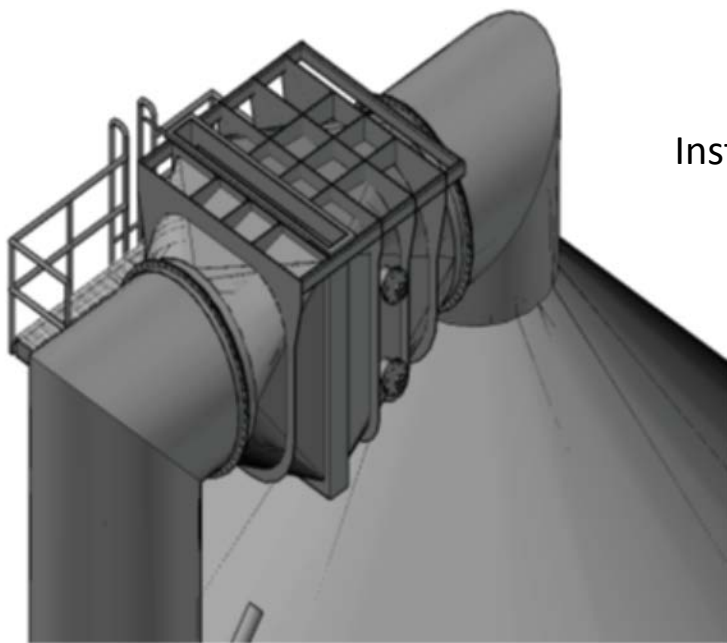

Side View

Install new mist eliminator housing;  
weld inlet and outlet flanges.

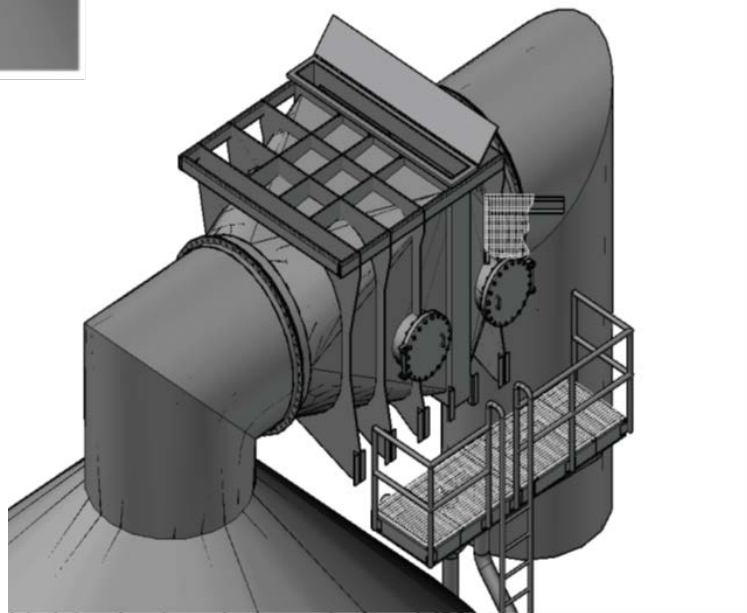

Access Side View

**NEW MIST ELIMINATOR WITH HOUSING INSTALLED**

Install new upper and lower platforms with new caged ladder.

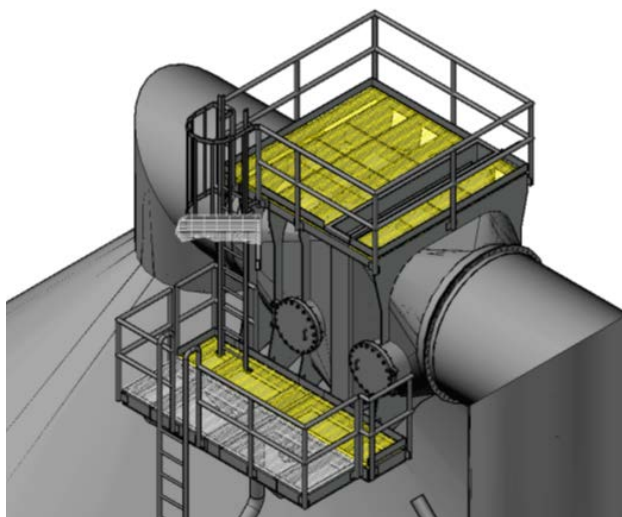
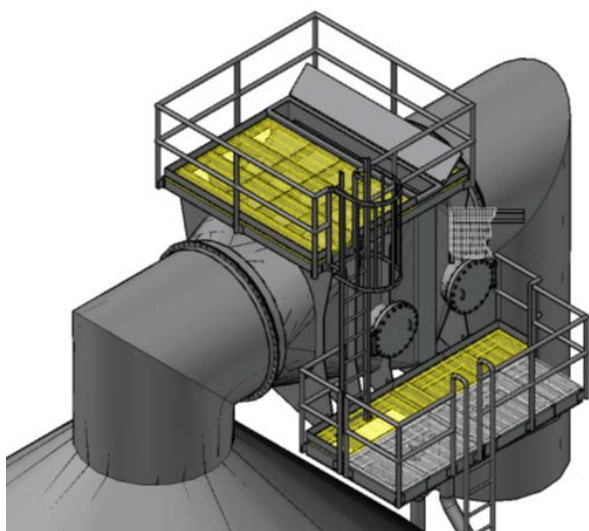

## NEW MIST ELIMINATOR PLATFORMS INSTALLED

AIROL®  
430H125  
Module 1 of 8

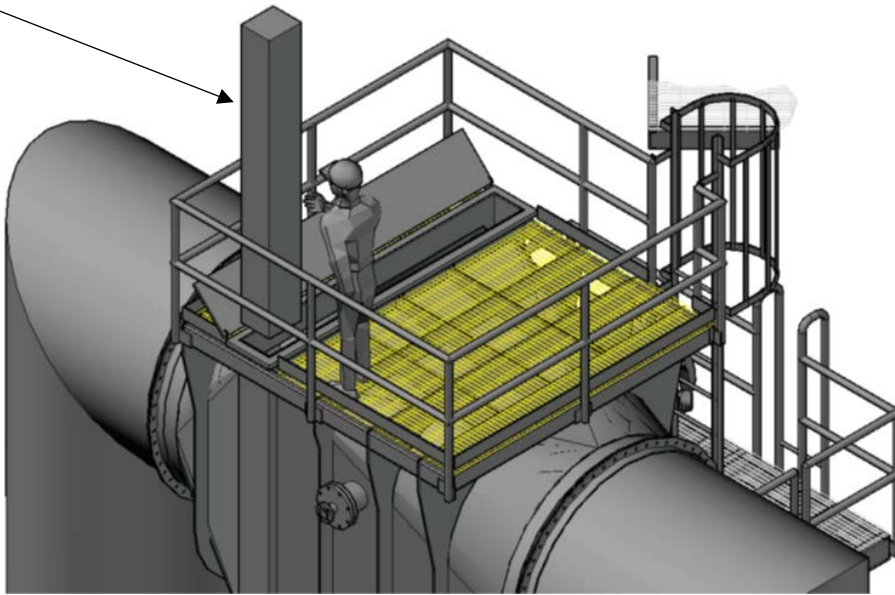

**INSTALLING NEW CHEVRON MODULES**

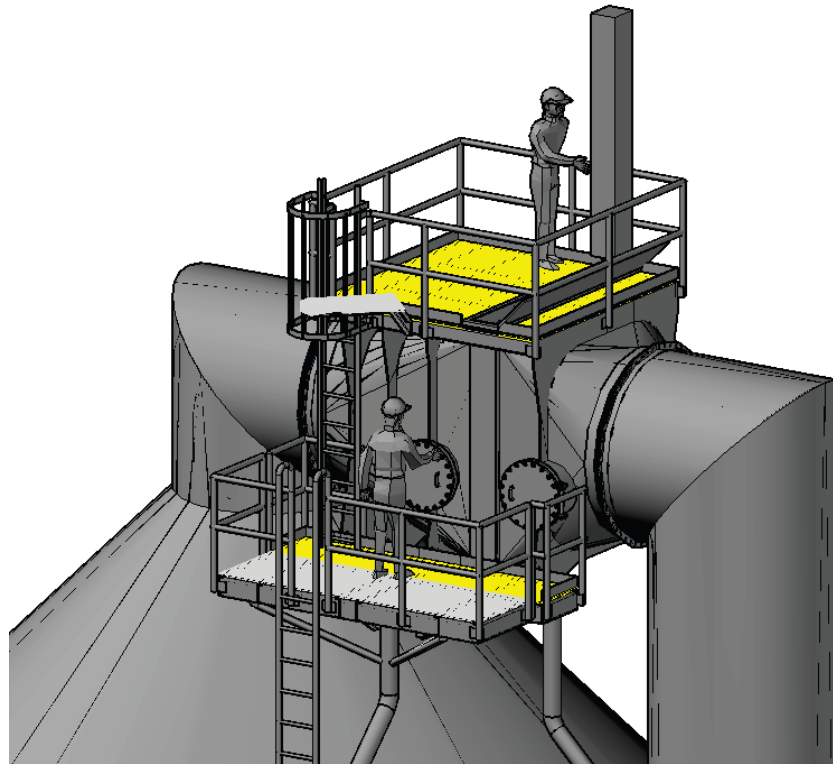

**FINISHED INSTALLATION**

*Coastal Technologies is the market leader in supplying pulp and paper evaporator mist eliminators world-wide for both new and retrofit applications.*

## CFD MODELING OF TURNING VANES to insure uniform flow across mist eliminator.

Without Turning Vanes

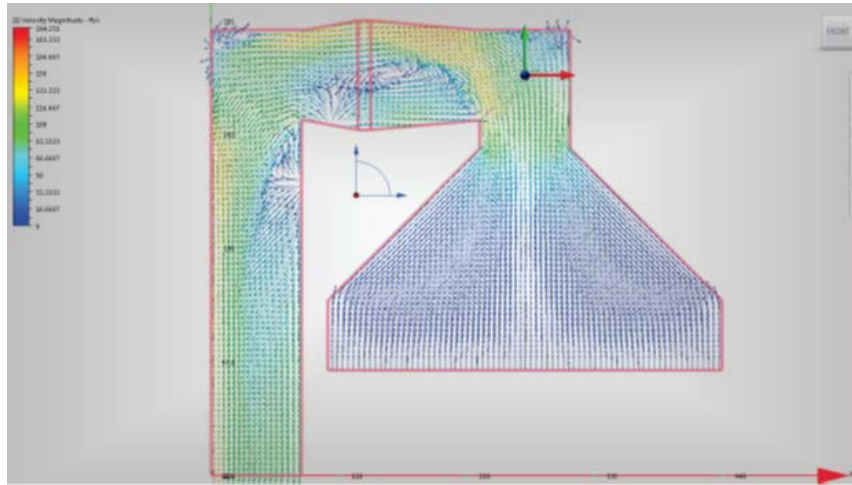

**CFD MODEL  
PRELIMINARY RESULTS**

With Turning Vanes

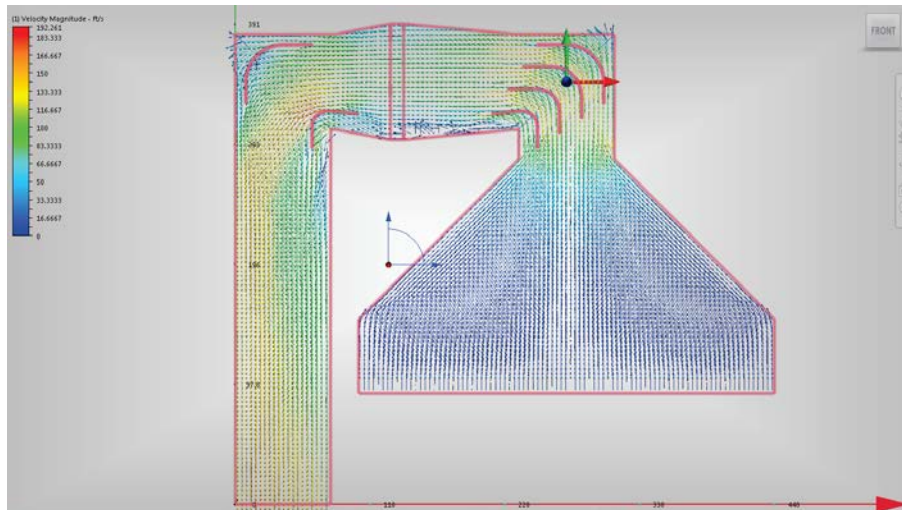

**CFD MODEL FINAL RESULTS**